

- Properties and loads are based on Grade 550 Steel with a minimum yield stress of 550 MPa and a maximum stress under factored loads of 324 MPa.
- Figures in Row B indicate the load capacity based on strength. Strength capacity B should be checked against [Specified Live Load] + [0.833 x Specified Dead Load].
- Figures in Row D indicate the load capacity based on deflection of 1/180th span. For allowable deflection of 1/90th span, values in Row D can be doubled, but must not exceed the figure in Row B. Deflection capacity should be checked against Specified Load(s).
- Specified web crippling capacity should be checked against specified load at support location.

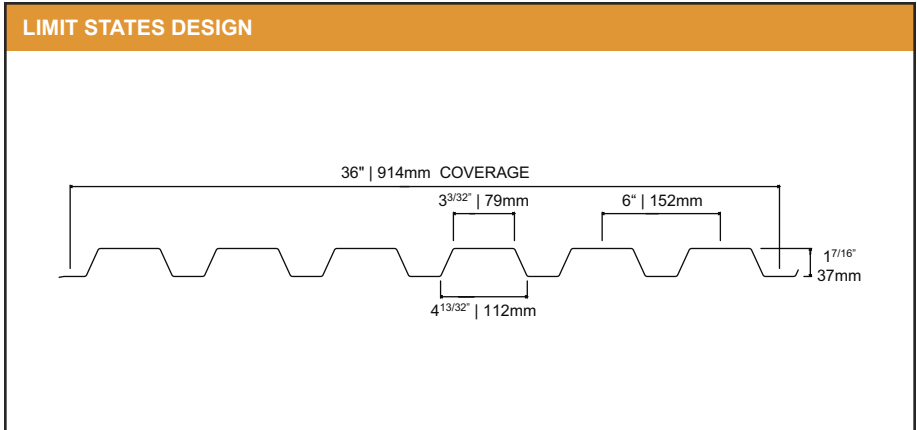

PHYSICAL PROPERTIES | Per Metre Width in accordance with CSA Specification S136-94.

Base Steel Nominal Thickness (mm)	Nominal Thickness Z275 Coating (mm)	Mass with Z275 Coating (kg/m ²)	Section Modulus		Moment of Inertia Midspan (mm ⁴ x 10 ³)	Factored Resistance Moment		Specified Crippling Bearing [mm] = 61	
			Midspan (mm ³ x 10 ³)	Support (mm ³ x 10 ³)		Midspan (N-m)	Support (N-m)	End (N/m)	Interior (N/m)
0.381	0.419	3.88	3.290	3.516	77.743	1066	1139	3473	4480
0.457	0.495	4.59	4.215	4.468	98.268	1366	1448	4816	6159
0.610	0.648	6.00	6.312	6.571	142.882	2045	2129	8027	10230
0.762	0.800	7.41	8.699	8.871	195.880	2818	2874	11923	15236
0.914	0.953	8.82	11.317	11.317	251.241	3667	3667	16491	21117

LOAD TABLE | Maximum Specified Uniformly Distributed Load in kN/m² (kPa).

Span (mm)		1-Span Base Steel Nominal Thickness (mm)				2-Span Base Steel Nominal Thickness (mm)				3-Span Base Steel Nominal Thickness (mm)						
		0.381	0.457	0.610	0.762	0.914	0.381	0.457	0.610	0.762	0.914	0.381	0.457	0.610	0.762	0.914
1200	B	3.95	5.06	7.57	10.44	13.58	4.22	5.36	7.89	10.65	13.58	5.27	6.70	9.86	13.31	16.98
1200	D	3.90	4.93	7.16	9.82	12.59	9.39	11.86	17.25	23.65	30.33	7.36	9.30	13.52	18.54	23.78
1350	B	3.12	4.00	5.98	8.25	10.73	3.33	4.24	6.23	8.41	10.73	4.17	5.30	7.79	10.51	13.41
1350	D	2.74	3.46	5.03	6.90	8.84	6.59	8.33	12.12	16.61	21.31	5.17	6.53	9.50	13.02	16.70
1500	B	2.53	3.24	4.85	6.68	8.69	2.70	3.43	5.05	6.81	8.69	3.38	4.29	6.31	8.52	10.86
1500	D	2.00	2.52	3.67	5.03	6.45	4.81	6.07	8.83	12.11	15.53	3.77	4.76	6.92	9.49	12.17
1650	B	2.09	2.68	4.01	5.52	7.18	2.23	2.84	4.17	5.63	7.18	2.79	3.54	5.21	7.04	8.98
1650	D	1.50	1.89	2.75	3.78	4.84	3.61	4.56	6.64	9.10	11.67	2.83	3.58	5.20	7.13	9.15
1800	B	1.75	2.25	3.37	4.64	6.04	1.88	2.38	3.50	4.73	6.04	2.34	2.98	4.38	5.91	7.54
1800	D	1.15	1.46	2.12	2.91	3.73	2.78	3.52	5.11	7.01	8.99	2.18	2.76	4.01	5.49	7.04
1950	B	1.50	1.92	2.87	3.95	5.14	1.60	2.03	2.99	4.03	5.14	2.00	2.54	3.73	5.04	6.43
1950	D	0.91	1.15	1.67	2.29	2.93	2.19	2.77	4.02	5.51	7.07	1.71	2.17	3.15	4.32	5.54
2100	B	1.29	1.65	2.47	3.41	4.43	1.38	1.75	2.57	3.48	4.43	1.72	2.19	3.22	4.34	5.54
2100	D	0.73	0.92	1.34	1.83	2.35	1.75	2.21	3.22	4.41	5.66	1.37	1.74	2.52	3.46	4.44
2250	B	1.12	1.44	2.15	2.97	3.86	1.20	1.52	2.24	3.03	3.86	1.50	1.91	2.80	3.78	4.83
2250	D	0.59	0.75	1.09	1.49	1.91	1.42	1.80	2.62	3.59	4.60	1.12	1.41	2.05	2.81	3.61
2400	B	0.99	1.26	1.89	2.61	3.40	1.05	1.34	1.97	2.66	3.40	1.32	1.68	2.46	3.33	4.24
2400	D	0.49	0.62	0.90	1.23	1.57	1.17	1.48	2.16	2.96	3.79	0.92	1.16	1.69	2.32	2.97
2550	B	0.87	1.12	1.68	2.31	3.01	0.93	1.19	1.75	2.36	3.01	1.17	1.48	2.18	2.95	3.76
2550	D	0.41	0.51	0.75	1.02	1.31	0.98	1.24	1.80	2.46	3.16	0.77	0.97	1.41	1.93	2.48
2700	B	0.78	1.00	1.50	2.06	2.68	0.83	1.06	1.56	2.10	2.68	1.04	1.32	1.95	2.63	3.35
2700	D	0.34	0.43	0.63	0.86	1.11	0.82	1.04	1.51	2.08	2.66	0.65	0.82	1.19	1.63	2.09
2850	B	0.70	0.90	1.34	1.85	2.41	0.75	0.95	1.40	1.89	2.41	0.94	1.19	1.75	2.36	3.01
2850	D	0.29	0.37	0.53	0.73	0.94	0.70	0.89	1.29	1.77	2.26	0.55	0.69	1.01	1.38	1.77
3000	B	0.63	0.81	1.21	1.67	2.17	0.68	0.86	1.26	1.70	2.17	0.84	1.07	1.58	2.13	2.72
3000	D	0.25	0.32	0.46	0.63	0.81	0.60	0.76	1.10	1.51	1.94	0.47	0.60	0.87	1.19	1.52

- Properties and loads are based on Grade 80 Steel with a minimum yield stress of 80,000 psi and a maximum stress under factored loads of 46,980 psi.
- Figures in Row B indicate the load capacity based on strength. Strength capacity B should be checked against [Specified Live Load] + [0.833 x Specified Dead Load].
- Figures in Row D indicate the load capacity based on deflection of 1/180th span. For allowable deflection of 1/90th span, values in Row D can be doubled, but must not exceed the figure in Row B. Deflection capacity should be checked against Specified Load(s).
- Specified web crippling capacity should be checked against specified load at support location.

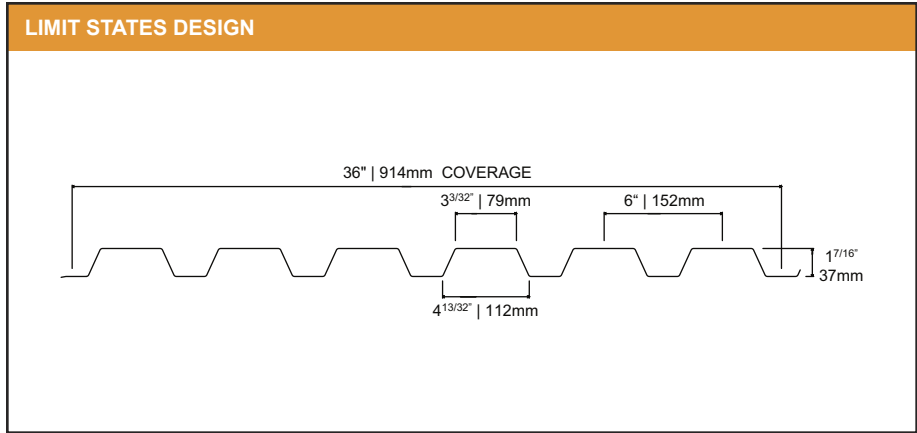

PHYSICAL PROPERTIES | Per Metre Width in accordance with CSA Specification S136-94.

Base Steel Nominal Thickness (inches)	Nominal Thickness Z275 Coating (inches)	Mass with Z275 Coating (lb/ft ²)	Section Modulus		Moment of Inertia Midspan (in ⁴)	Factored Resistance Moment		Specified Crippling Bearing [mm] = 2.0	
			Midspan (in ³)	Support (in ³)		Midspan (ft-lb)	Support (ft-lb)	End (lbs/ft)	Interior (lbs/ft)
0.0150	0.0165	0.87	0.0612	0.0654	0.0569	239.60	256.04	238	307
0.0180	0.0195	1.03	0.0784	0.0831	0.0720	306.94	325.34	330	422
0.0240	0.0255	1.35	0.1174	0.1222	0.1046	459.62	478.49	550	701
0.0300	0.0315	1.67	0.1618	0.1650	0.1434	633.45	645.98	817	1044
0.0360	0.0375	1.98	0.2105	0.2105	0.1840	824.11	824.11	1130	1477

LOAD TABLE | Maximum Specified Uniformly Distributed Load in lb/ft² (psf).

Span (ft)		1-Span Base Steel Nominal Thickness (inches)					2-Span Base Steel Nominal Thickness (inches)					3-Span Base Steel Nominal Thickness (inches)				
		0.015	0.018	0.024	0.030	0.036	0.015	0.018	0.024	0.030	0.036	0.015	0.018	0.024	0.030	0.036
4.0	B	80	102	153	211	275	85	108	159	215	275	107	136	199	269	343
	D	78	98	143	196	251	187	236	344	471	604	147	185	269	369	473
4.5	B	63	81	121	167	217	67	86	126	170	217	84	107	158	213	271
	D	55	69	100	137	176	131	166	241	331	424	103	130	189	259	333
5.0	B	51	65	98	135	176	55	69	102	138	176	68	87	128	172	220
	D	40	50	73	100	128	96	121	176	241	309	75	95	138	189	242
5.5	B	42	54	81	112	145	45	57	84	114	145	56	72	105	142	182
	D	30	38	55	75	96	72	91	132	181	232	56	71	104	142	182
6.0	B	35	45	68	94	122	38	48	71	96	122	47	60	89	120	153
	D	23	29	42	58	74	55	70	102	140	179	43	55	80	109	140
6.5	B	30	39	58	80	104	32	41	60	82	104	40	51	76	102	130
	D	18	23	33	46	58	44	55	80	110	141	34	43	63	86	110
7.0	B	26	33	50	69	90	28	35	52	70	90	35	44	65	88	112
	D	14	18	27	36	47	35	44	64	88	113	27	35	50	69	88
7.5	B	23	29	44	60	78	24	31	45	61	78	30	39	57	77	98
	D	12	15	22	30	38	28	36	52	71	92	22	28	41	56	72
8.0	B	20	26	38	53	69	21	27	40	54	69	27	34	50	67	86
	D	10	12	18	24	31	23	30	43	59	76	18	23	34	46	59
8.5	B	18	23	34	47	61	19	24	35	48	61	24	30	44	60	76
	D	8	10	15	20	26	19	25	36	49	63	15	19	28	38	49
9.0	B	16	20	30	42	54	17	21	32	43	54	21	27	39	53	68
	D	7	9	13	17	22	16	21	30	41	53	13	16	24	32	42
9.5	B	14	18	27	37	49	15	19	28	38	49	19	24	35	48	61
	D	6	7	11	15	19	14	18	26	35	45	11	14	20	28	35
10.0	B	13	16	25	34	44	14	17	26	34	44	17	22	32	43	55
	D	5	6	9	13	16	12	15	22	30	39	9	12	17	24	30